



UNIVERSITY OF CAMBRIDGE INTERNATIONAL EXAMINATIONS
International General Certificate of Secondary Education

CANDIDATE
NAME

CENTRE
NUMBER

--	--	--	--	--

CANDIDATE
NUMBER

--	--	--	--

PHYSICS

0625/31

Paper 3 Extended

May/June 2012

1 hour 15 minutes

Candidates answer on the Question Paper.

No Additional Materials are required.

READ THESE INSTRUCTIONS FIRST

Write your Centre number, candidate number and name on all the work you hand in.

Write in dark blue or black pen.

You may use a pencil for any diagrams or graphs.

Do not use staples, paper clips, highlighters, glue or correction fluid.

DO NOT WRITE IN ANY BARCODES.

Answer **all** questions.

You may lose marks if you do not show your working or if you do not use appropriate units.

Take the weight of 1 kg to be 10 N (i.e. acceleration of free fall = 10 m/s^2).

At the end of the examination, fasten all your work securely together.

The number of marks is given in brackets [] at the end of each question or part question.

For Examiner's Use

1	
2	
3	
4	
5	
6	
7	
8	
9	
10	
11	
Total	

This document consists of **12** printed pages.



1 The period of the vertical oscillations of a mass hanging from a spring is known to be constant.

(a) A student times single oscillations with a stopwatch. In 10 separate measurements, the stopwatch readings were:

1.8s, 1.9s, 1.7s, 1.9s, 1.8s, 1.8s, 1.9s, 1.7s, 1.8s, 1.8s.

What is the best value obtainable from these readings for the time of one oscillation? Explain how you arrive at your answer.

best value =

explanation

.....

..... [1]

(b) Describe how, using the same stopwatch, the student can find the period of oscillation more accurately.

.....

.....

.....

.....

.....

.....

..... [4]

[Total: 5]

- 2 A girl rides her bicycle along a straight level road. Fig. 2.1 shows a graph of her distance moved against time.

For
Examiner's
Use

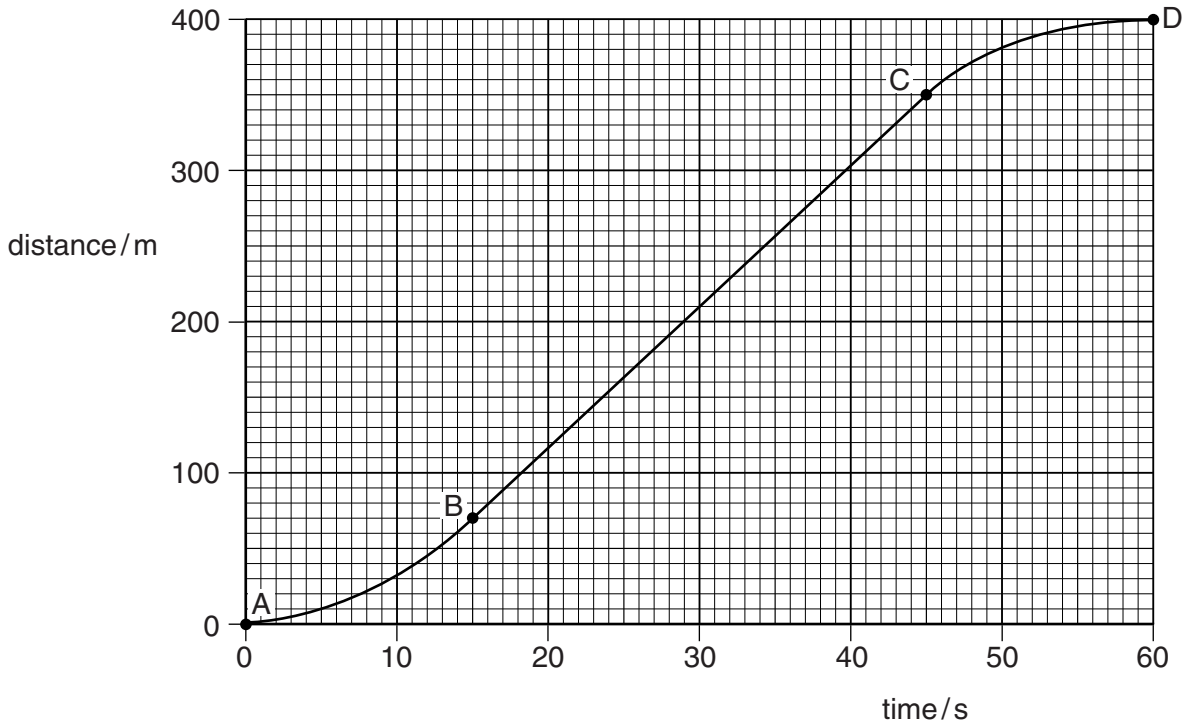

Fig. 2.1

(a) Describe her motion

(i) from A to B,

(ii) from B to C,

(iii) from C to D.

[3]

(b) Calculate

(i) her average speed from A to D,

average speed = [2]

(ii) her maximum speed.

maximum speed = [3]

[Total: 8]

- 3 (a) State an example of the conversion of chemical energy to another form of energy.

example

energy conversion [1]

- (b) The electrical output of a solar panel powers a pump. The pump operates a water fountain. The output of the solar panel is 17 V and the current supplied to the pump is 0.27 A.

- (i) Calculate the electrical power generated by the solar panel.

power = [2]

- (ii) The pump converts electrical energy to kinetic energy of water with an efficiency of 35%.

Calculate the kinetic energy of the water delivered by the pump in 1 second.

kinetic energy = [2]

- (iii) The pump propels 0.00014 m^3 of water per second. This water rises vertically as a jet. The density of water is 1000 kg/m^3 .

Calculate

1. the mass of water propelled by the pump in 1 second,

mass = [2]

2. the maximum height of the jet of water.

maximum height = [2]

[Total: 9]

4 Fig. 4.1 represents part of the hydraulic braking system of a car.

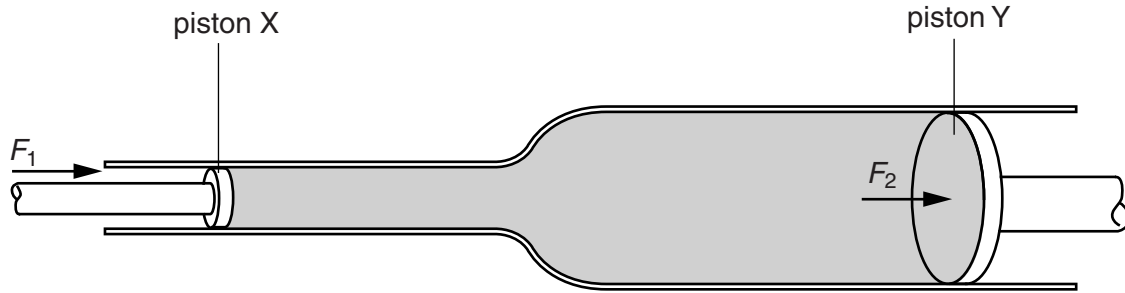

Fig. 4.1

The force F_1 of the driver's foot on the brake pedal moves piston X. The space between pistons X and Y is filled with oil which cannot be compressed. The force F_2 exerted by the oil moves piston Y. This force is applied to the brake mechanism in the wheels of the car.

The area of cross-section of piston X is 4.8 cm^2 .

(a) The force F_1 is 90 N. Calculate the pressure exerted on the oil by piston X.

pressure = [2]

(b) The pressure on piston Y is the same as the pressure applied by piston X. Explain why the force F_2 is greater than the force F_1 .

.....
 [1]

(c) Piston Y moves a smaller distance than piston X. Explain why.

.....

 [2]

(d) Suggest why the braking system does not work properly if the oil contains bubbles of air.

.....

 [2]

[Total: 7]

5 (a) Suggest

(i) an example of a change of state resulting from the removal of thermal energy from a quantity of material,

..... [1]

(ii) the effect of this change of state on the temperature of the material.

..... [1]

(b) Define the *thermal capacity* of a body.

.....
.....
..... [2]

(c) A polystyrene cup holds 250g of water at 20°C. In order to cool the water to make a cold drink, small pieces of ice at 0°C are added until the water reaches 0°C and no unmelted ice is present.

[specific heat capacity of water = 4.2J/(g°C), specific latent heat of fusion of ice = 330J/g]

Assume no thermal energy is lost or gained by the cup.

(i) Calculate the thermal energy lost by the water in cooling to 0°C.

thermal energy lost = [2]

(ii) State the thermal energy gained by the ice in melting.

thermal energy gained = [1]

(iii) Calculate the mass of ice added.

mass of ice = [2]

[Total: 9]

- 6 Fig. 6.1 shows a glass flask full of water at 10°C and sealed with a bung. A long glass tube passes through the bung into the water. The water level in the tube is at X.

For
Examiner's
Use

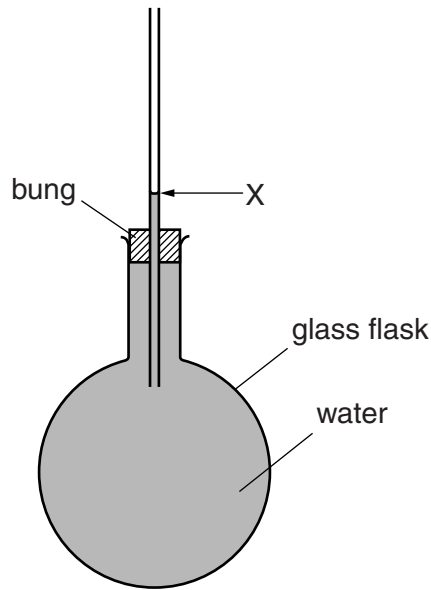

Fig. 6.1

When the flask is placed in hot water, the water level initially falls a little below X, and then rises some way above X.

(a) Suggest why

(i) the water level initially falls,

.....
 [2]

(ii) the water level then rises,

.....
 [2]

(iii) the rise is greater than the fall.

.....
 [1]

(b) Suggest a change to the apparatus that would make the fall and rise of the water level greater.

.....
 [1]

[Total: 6]

- 7 (a) A wave passes along the surface of the water in a ripple tank. Describe the motion of a molecule on the surface as the wave passes.

.....
 [1]

- (b) Fig. 7.1 shows a view from above of water waves approaching a narrow gap in a barrier. The water on both sides of the barrier has the same depth.

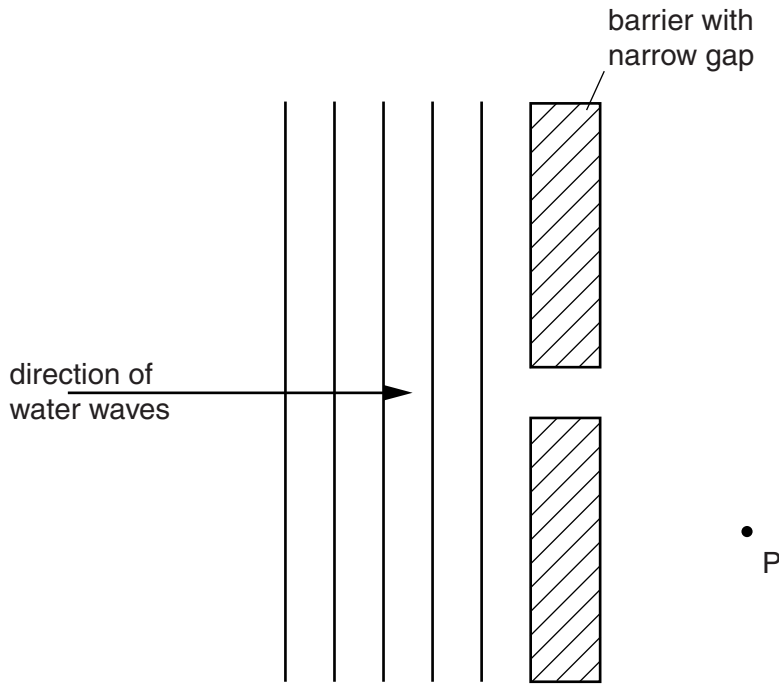

Fig. 7.1

- (i) On Fig. 7.1, sketch the pattern of waves in the region to the right of the barrier. [2]
 (ii) State the process by which waves arrive at point P to the right of the barrier.

..... [1]

- (c) The waves approaching the barrier in Fig. 7.1 have a wavelength of 1.4 cm and travel at a speed of 12 cm/s.

Calculate the frequency of the waves.

frequency = [2]

[Total: 6]

- 8 (a) In Fig. 8.1, S is a metal sphere standing on an insulating base. R is a negatively charged rod placed close to S.

For
Examiner's
Use

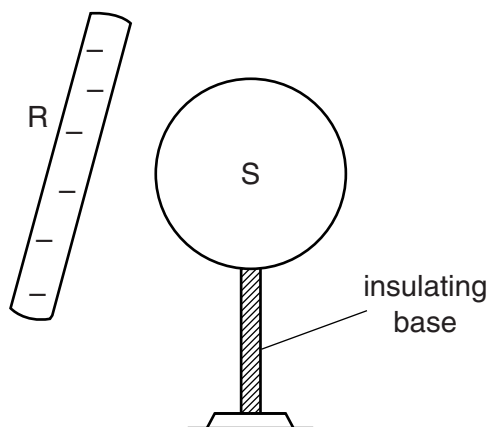

Fig. 8.1

- (i) Name the particles in S that move when R is brought close to S.

..... [1]

- (ii) On Fig. 8.1, add + signs and – signs to suggest the result of this movement. [1]

- (iii) Describe the actions which now need to take place so that S becomes positively charged with the charge distributed evenly over its surface. A positively charged object is **not** available.

.....

 [3]

- (b) During a thunderstorm, the potential difference between thunderclouds and the ground builds up to 1.5×10^6 V. In each stroke of lightning, 30 C of charge passes between the thunderclouds and the ground. Lightning strokes to the ground occur, on average, at 2 minute intervals.

Calculate

- (i) the average current between the thunderclouds and the ground,

average current = [2]

- (ii) the energy transferred in each stroke of lightning.

energy = [2]

[Total: 9]

9 This question refers to quantities and data shown on the circuit diagram of Fig. 9.1.

For
Examiner's
Use

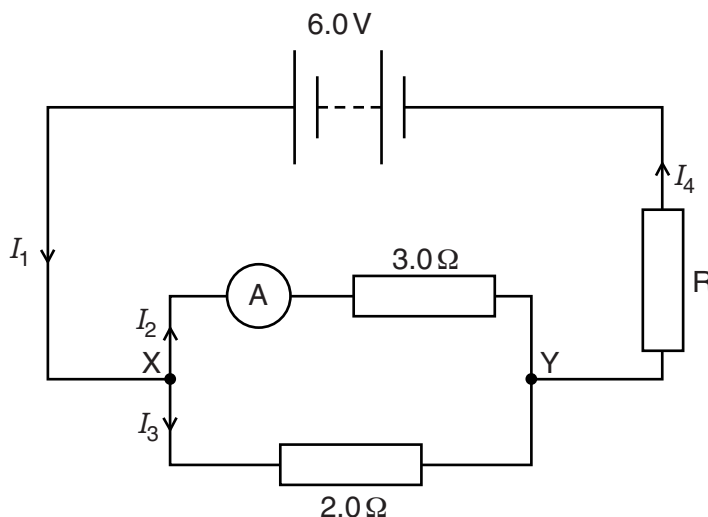

Fig. 9.1

(a) State the relationship between

(i) the currents I_1 , I_2 and I_3 , [1]

(ii) the currents I_1 and I_4 [1]

(b) The ammeter reads 0.80 A. Assume it has zero resistance.

Calculate

(i) the potential difference between X and Y,

p.d. = [1]

(ii) the current I_3 ,

current = [2]

(iii) the resistance of R.

resistance = [4]

[Total: 9]

- 10 (a) Fig. 10.1 shows a wire PQ placed between the poles of a magnet. There is a current in wire PQ.

For
Examiner's
Use

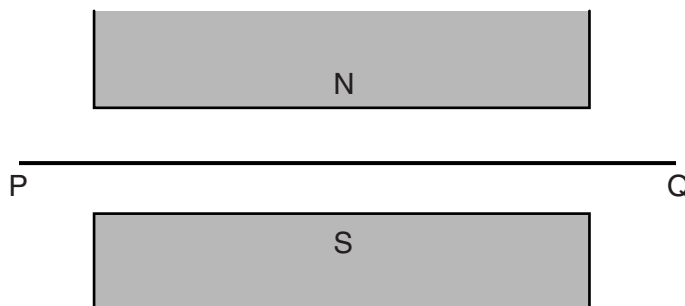

Fig. 10.1

- (i) On Fig. 10.1, sketch lines with arrows to show the direction of the magnetic field between the poles of the magnet. [1]
- (ii) The force on PQ is into the paper.
Draw an arrow on PQ to show the direction of the current. [1]
- (b) The wire PQ in Fig. 10.1 is replaced by a narrow beam of β -particles travelling from left to right.
 - (i) Suggest a suitable detector for the β -particles.
..... [1]
 - (ii) State the direction of the force on the β -particles.
..... [1]
 - (iii) Describe the path of the β -particles in the space between the poles of the magnet.
.....
..... [1]
 - (iv) State what happens to the air molecules along the path of the β -particles.
..... [1]

[Total: 6]

Question 11 is on the next page.

11 Fig. 11.1 shows part of a circuit designed to switch on a security lamp when it gets dark.

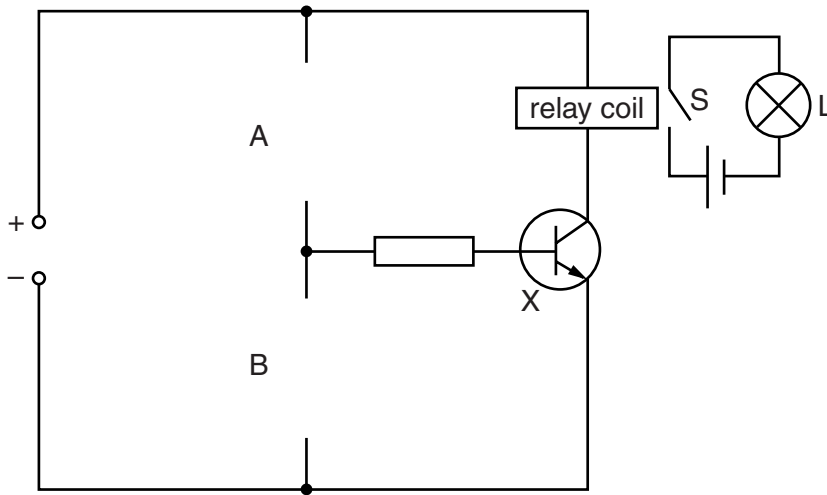

Fig. 11.1

When there is a current in the relay coil, switch S closes and the lamp L comes on.

(a) Write down the name of the component X. [1]

(b) The circuit has gaps at A and at B.

State the components that need to be connected into these gaps for the circuit to perform its required function.

gap A

gap B

[3]

(c) The circuit in Fig. 11.1 is modified. The function of lamp L is now to give a warning when the temperature becomes too high.

State any necessary changes of components in the circuit.

.....

[2]

[Total: 6]

Permission to reproduce items where third-party owned material protected by copyright is included has been sought and cleared where possible. Every reasonable effort has been made by the publisher (UCLES) to trace copyright holders, but if any items requiring clearance have unwittingly been included, the publisher will be pleased to make amends at the earliest possible opportunity.

University of Cambridge International Examinations is part of the Cambridge Assessment Group. Cambridge Assessment is the brand name of University of Cambridge Local Examinations Syndicate (UCLES), which is itself a department of the University of Cambridge.